

Securing *AntPro*[™] Dispenser to Ground Surfaces with Additional Stakes

1. Drill 2 holes in base ramp
2. Cut 28 inch welding rod (or similar) in half
3. Bend end of each rod with vice grips
4. Insert the now 13 inch rods through the base ramp, criss crossing, then diagonally across the center stake in the ground

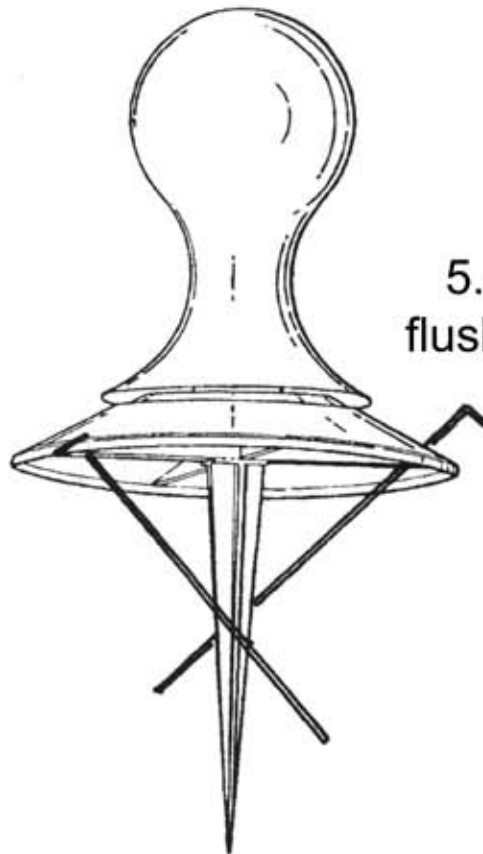

5. Insert rods, flush to base surface

6. Use pliers to remove staking rods

Materials Needed:

- Pliers or Vice Grips
- Hammer
- Metal Shears
- Welding Rod or Similar
- Drill and Bit